

U2 Tilt product information sheet

Product Specifications

Fits most: 23" - 42" flat panels

Supports up to: 80 lbs (36.3 kg)

Tilt: -5° to +15°

Mounting profile: 2.3" (58mm)

Universal & VESA compliant: 100x100 to 300x400

Mounting: Single- or Double-stud

UL listed: Yes

Warranty: 5 years

Color: Black and Platinum

Product Benefits

- Tilt -5° to +15° to reduce glare
- Universal rails for greater panel compatibility
- Lift n' Lock™ allows you to easily attach your flat panel to the mount
- Tension adjustment for variable tilt
- Sliding lateral on-wall adjustment
- Open architecture provides easy access to in-wall wiring
- Locking system secures panel to mount

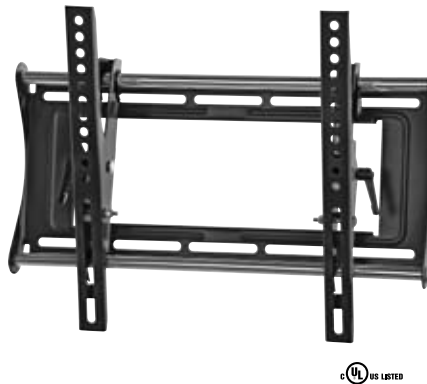

- Rail hooks are padded to avoid metal-on-metal contact and reduce vibration
- Installation template for simple and accurate mounting
- Includes complete hardware kit



The U2 Tilt comes with an installation template to ensure a quick, easy and accurate installation

Series



75/100 FD



QM100 T*



U2 Fixed**

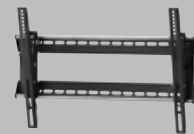

U3 Tilt***



75/100 CL

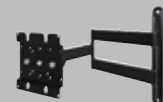

FP-CL



UCL

* also available in small and medium fixed
** also available in large/extra large
*** also available in small and medium

OmniMount, an innovator of A/V mounts and furniture for more than a quarter century, is the choice of professional installers and the brand most recommended by flat panel manufactures. The Classic Series is a full line of fixed, tilt, flip down and cantilever mounting solutions designed with simplicity and reliability in mind. The U2 Tilt is a solid choice for any installation requiring a medium tilt mount with universal compatibility.



U2 Tilt technical data sheet



OmniMount, an innovator of A/V mounts and furniture for more than a quarter century, is the choice of professional installers and the brand most recommended by flat panel manufactures. The Classic Series is a full line of fixed, tilt, flip down and cantilever mounting solutions designed with simplicity and reliability in mind. The U2 Tilt is a solid choice for any installation requiring a medium tilt mount with universal compatibility.

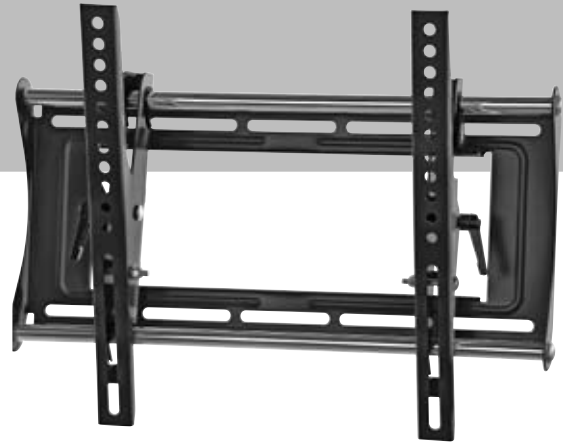

Product Specifications

Fits most: 23" - 42" flat panels

Supports up to: 80 lbs (36.3 kg)

Tilt: -5° to +15°

Mounting profile: 2.3" (58mm)

Universal & VESA compliant: 100x100 to 300x400

Mounting: Single- or Double-stud

UL listed: Yes

Warranty: 5 years

Color: Black and Platinum

Product Benefits

- Tilt -5° to +15° to reduce glare
- Universal rails for greater panel compatibility
- Lift n' Lock™ allows you to easily attach your flat panel to the mount
- Tension adjustment for variable tilt
- Sliding lateral on-wall adjustment
- Open architecture provides easy access to in-wall wiring
- Locking system secures panel to mount
- Rail hooks are padded to avoid metal-on-metal contact and reduce vibration
- Installation template for simple and accurate mounting
- Includes complete hardware kit

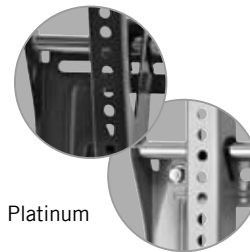

Black

Platinum

cUL LISTED

	Color	Stock Code	Packaging UPC	MC UPC	Dimensions WxDxH inches (mm)	Wt lbs (kg)
Americas	Black	1002775-1	728901014598	728901707810	Product Box 9.9 x 20.1 x 2.4 (251x510x62)	10.6 (4.8)
International	Black	1002775EU-1	728901017841	728901711152		
Americas	Platinum	1002270-1	728901014390	728901707568	Master Carton 10.5 x 20.7 x 5.5 (267x526x140)	21.2 (9.6)
International	Platinum	1002305-1	728901014802	728901708060		

Box Contents	Qty
Wall plate	1
Vertical tilt rail	2
Installation template	1
Complete mount installation hardware kit	1
Complete panel attachment hardware kit	1
Instruction manual	1
Flat panel compatibility chart	1

U2 Tilt line drawing

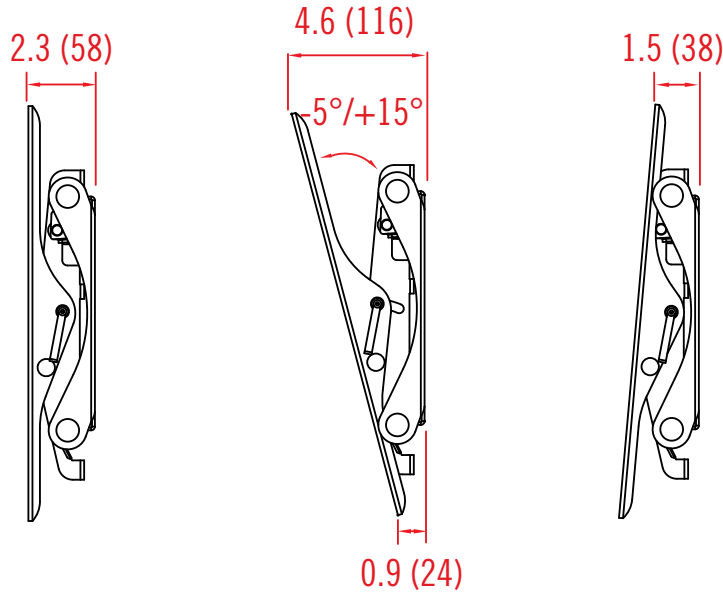
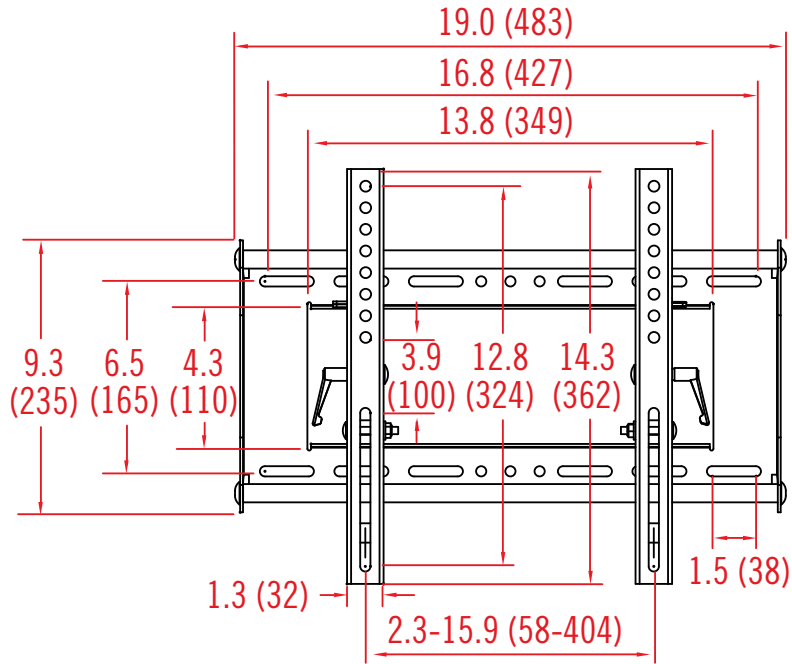

inches (mm)